

REVISION NO. 1

(EFFECTIVE . . . MARCH 31, 1981)

TO

STATE OF ILLINOIS

ACCESSIBILITY STANDARDS, ILLUSTRATED

EDITION . . . JUNE 1978

(EFFECTIVE . . . DECEMBER 28, 1978)



**Capital Development Board
Donald S. Glickman,
Executive Director**

CONTENTS

	Page No.
General Index	1
Comprehensive Application Index	2
Revisions	9
Statutory References (Excerpts)	33

P R E F A C E

REVISION NO. 1 includes **all** revisions approved from the date the original **Accessibility Standards** was printed (June, 1978) through and including those approved March 31, 1981.

Only 2 documents are now needed to determine accessibility – the original **Standards** (with the orange stripe) **and Revision No. 1.**

Revision No. 1 includes a Comprehensive Application Index showing the exact document location of the Section/Figure/Table currently in effect.

Revision No. 1 includes appropriate statutory references from the 1979 Illinois Revised Statutes.

GENERAL INDEX
() Denotes Supplementary Reference Page.

Section Number/Title	Page Number Access. Revi- Stds. sion No. 1	Section Number/Title	Page Number Access. Revi- Stds. sion No. 1
GENERAL INFORMATION		12. Communication and Identification	140
1.	1 (9)	12.1 Signage	140 (25)
HUMAN DATA		12.2 Emergency Warning Signals and Alarms.	144 (25)
2.	7	12.3 Tactile Warning Signals and Blind Location Cues	148
SITE DEVELOPMENT		13.1 Ground and Floor Surfaces	152
3.1 Exterior Circulation Routes	34	BUILDING PRODUCTS	
3.2 Walks, Sidewalks	36	14.1 Location of Controls, Dispensers and Receptacles.	156
3.3 Curb Ramps	42	14.2 Supports	158
3.4 Street Crossings	50	14.3 Electrical Fixtures and Controls.	158
3.5 Parking	54 (10)	14.4 Plumbing Fixtures	160
3.6 Pedestrian Gates and Turnstiles	58	15.1 Appliances for Public Use	162
3.7 Site Furniture	58	ADDITIONAL REQUIREMENTS FOR SPECIFIC BUILDING TYPES	
3.8 Locatable Barriers.	64	16.1 Residential Structures	164 (25)
3.9 Controls, Dispensers and Receptacles.	66	16.2 Hotels, Motels.	166
3.10 Selection of Building Products and Materials	66	16.3 Educational Buildings, Libraries and Museums	170
3.11 Exterior Stairs and Ramps.	66	16.4 Health Facilities.	174
3.12 Exterior Pay Telephones.	66	16.5 Transportation Terminals and Stations	174
3.13 Landscaping	68	16.6 Recreation Facilities	176
BUILDING ELEMENTS		16.7 Auditoria, Arenas, Assembly Halls and Stadia	180
4.1 Entrance Doors and Doorways	70	16.8 Serving Counters, Seating, Fixed Tables and Work Surfaces	26
4.2 Door Handles	80 (10)	16.9 Dining Halls - Restaurants	186 (27)
4.3 Door Signs.	82	16.10 Shopping Centers - Grocery Stores	188
5.1 Interior Circulation Routes	84 (10)	REMODELING	
6.1 Ramps	88 (10)	17.1 Remodeling	28
6.2 Stairs	96 (13)	17.2 General Requirements	29
6.3 Handrails and Guardrails.	100	17.3 Major Remodeling Requirements	29
7. Vertical Circulation.	15	17.4 Remodeling Requirements - Small Buildings	30
7.1 Elevators	15	17.5 Remodeling Requirements - Medium Size Buildings	30
7.2 Platform Lifts	20	17.6 Remodeling Requirements - Large Buildings	31
8.1 Public Toilet Rooms	116 (21)	HISTORIC PRESERVATION	
9.1 Drinking Fountains.	128	18.1 Historic Preservation and Historic Reconstruction	198
10.1 Shower Rooms	132		
11.1 Coin Operated Public and Semi-Public Telephones	134		

COMPREHENSIVE APPLICATION INDEX

NOTE: This index has been developed to facilitate the user determining those sections/ figures/tables which are currently in effect following filing of **Revision No. 1** with the office of the Secretary of State on March 31, 1981. The index also indicates the page number of the appropriate document where each section/figure/ table currently in effect is located.

- * Denotes revised or new sections
- Denotes revised or new figures/tables

Section No. - Title/Figure/Table	Page Number Access. Stds.	Revi- sion No. 1
GENERAL INFORMATION		
1.1.1 Scope	1	
1.1.2 Purpose	1	
* 1.1.3 Definitions	1	9
1.1.4 Plans & Specs to meet Stds.	6	
1.1.5 Enforcement Violations	6	
* 1.1.6 Revisions to Standards	6	9
1.1.7 Severability Clause	6	

HUMAN DATA

2.1 Human Data	7
2.2 Walking Disabilities	8
2.3 Wheelchair Users	10
2.3.1 Dimensions of Wheelchair	12
2.3.1 Figure	13
2.3.2 Space Requirements for Maneuvering Wheelchairs.	14
2.3.2A Figure	15
2.3.2B Figure	15
2.3.2C Figure	15
2.3.2D Figure	14
2.3.2D-1 Figure	14
2.3.3 Reaching from a wheelchair	16
2.3.3A Figure	16
2.3.3B Figure	17
2.3.4 Space Requirements for passing.	16
2.3.4A Figure	17
2.3.4B Figure	17
2.3.4C Figure	17
2.4 Chronic Impairment of Upper Extremities and Shoulders	18
2.4 Figure	19
2.5 Extremes of Size and/or Maturity.	20

Section No. - Title/Figure/Table	Page Number Access. Stds.	Revi- sion No. 1
2.5A Figure	20	
2.5B Figure	21	
2.5C Figure	21	
2.6 Chronic Restrictive Conditions Affecting Agility, Stamina, and Reaction Time.	22	
2.7 Severe Auditory Impairment	24	
2.8 Severe Visual Impairment	26	
2.8.1 Long Cane Technique	26	
2.8.2 Cueing Aids	28	
2.8.3 Color Blindness	30	
2.9 Obvious Confusion and/or Disorientation	30	
2.10 Difficulty Bending, Turning, Sitting, Kneeling and Rising	31	
2.11 Incontinence.	31	

SITE DEVELOPMENT

3.1 Exterior Circulation Routes	34
3.1.1	34
3.1.2	34
3.1.3	34
3.1.4	34
3.2 Walks, Sidewalks	36
3.2.1	36
3.2.1 Figure	37
3.2.2	36
3.2.3	36
3.2.3 Figure	37
3.2.4	38
3.2.5	38
3.2.6	38
3.2.7	38
3.2.7A Figure	39
3.2.7B Figure	39
3.2.7C Figure	39
3.2.8	38
3.2.8 Figure	39
3.2.9	40
3.2.9A Figure	41
3.2.9B Figure	41
3.2.9C Figure	41
3.2.9D Figure	41
3.2.9E Figure	41
3.2.10	42
3.2.10 Figure	43

COMPREHENSIVE INDEX

Section No. - Title/Figure/Table	Page Number Access. Revi- Std. sion No. 1	Section No. - Title/Figure/Table	Page Number Access. Revi- Std. sion No. 1
3.3 Curb Ramps	42	3.7.5	62
3.3.1	42	3.7.6	62
3.3.1 Figure	43	3.7.6 Figure	63
3.3.2	44	3.7.7	62
3.3.2 Figure	45	3.7.8	62
3.3.3	46	3.8 Locatable Barriers.	64
3.3.4	46	3.8.1	64
3.3.4A-1 Figure	47	3.8.2	64
3.3.4 Figure - Types A thru G	47 + 48	3.8.3	64
3.3.4FF Figure	49	3.8.4	64
3.3.5	50	3.8.4 Figure	65
3.4 Street Crossings	50	3.8.5	66
3.4 Figure	51	3.8.5 Figure	67
3.4.1	52	3.9 Controls, Dispensers and Receptacles	66
3.4.2	52	3.10 Selection of Building Products and Materials	66
3.4.2 Figure	53	3.11 Exterior Stairs and Ramps.	66
3.4.3	52	3.12 Exterior Pay Telephones.	66
3.4.4	52	3.13 Landscaping	68
3.5 Parking	54	3.13 Figure	69
3.5.1	54	3.13.1	68
* 3.5.2	10		
3.5.3	54		
3.5.3 Figure	55		
3.5.4	56		
3.5.5	56		
3.5.5 Table	56		
3.5.6	56		
3.5.6 Figure	57		
3.5.7	56		
3.5.8	56		
3.5.9	58		
3.5.9 Figure	59		
3.5.10	58		
3.5.11	58		
3.6 Pedestrian Gates and Turnstiles	58		
3.6.1	58		
3.6.2	58		
3.7 Site Furniture	58		
3.7.1	60		
3.7.2	60		
3.7.3	60		
3.7.4	60		
3.7.4 Figure	61		
		BUILDING ELEMENTS	
		4.1 Entrances, Doors and Doorways	70
		4.1.1	70
		4.1.1 Figure	71
		4.1.2	72
		4.1.3	72
		4.1.3 Figure	73
		4.1.4	72
		4.1.5	74
		4.1.5A Figure	75
		4.1.5B Figure	75
		4.1.5C Figure	75
		4.1.6	74
		4.1.6 Figure	75
		4.1.7	74
		4.1.7 Figure	75
		4.1.8	74
		4.1.9	74
		4.1.9 Figure	75
		4.1.10	76
		4.1.10 Figure	77

COMPREHENSIVE INDEX

Section No. - Title/Figure/Table	Page Number Access. Std.	Revi- sion No.1	Section No. - Title/Figure/Table	Page Number Access. Std.	Revi- sion No. 1
4.1.11	76		6.1 Ramps	88	
4.1.12	76		6.1.1		10
4.1.12 Figure	77		- 6.1.1 Revised Table		12
4.1.13	78		- 6.1.1 Revised Figure		12
4.1.13 Figure	77		6.1.2	88	
4.1.14	78		6.1.3	88	
4.1.15	78		6.1.4	88	
4.1.16	78		* 6.1.5		11
4.1.17	78		6.1.5 Figure	91	
4.1.18	78		6.1.6	90	
4.1.18 Figure	79		6.1.6 Figure	91	
4.2 Door Handles	80		6.1.7	90	
* 4.2.1		10	- 6.1.7 Revised Figure		12
4.2.1A Figure	81		* 6.1.8		11
4.2.1B Figure	81		- 6.1.8 Revised Figure		11
4.2.2	80		6.1.9	94	
4.2.3	80		6.1.9 Figure	95	
4.2.4	82		6.1.10	94	
4.2.4 Figure	83		6.1.11	94	
4.2.5	82		6.2 Stairs	96	
4.2.5 Figure	83		* 6.2.1		13
* 4.2.6		10	6.2.1 Figure		13
4.3 Door Signs	82		6.2.2	96	
4.3.1	82		* 6.2.3		13
4.3.1 Figure	83		* 6.2.3 Figure	97	
5.1 Interior Circulation Routes	84		- 6.2.3A Revised Figure		13
5.1.1	84		6.2.4	98	
5.1.2	84		6.2.4 Figure	99	
5.1.3	86		6.2.5	98	
5.1.4	86		* 6.2.6		14
5.1.4A Figure	87		6.2.6 Figure	99	
5.1.4B Figure	87		6.2.7	98	
5.1.4C Figure	87		6.2.8	98	
5.1.5	86		* 6.2.9		14
5.1.6	86		6.2.10	100	
5.1.6 Figure	87		6.2.10 Figure	101	
* 5.1.7		10	6.3 Handrails and Guardrails	100	
			6.3.1	100	
			6.3.2	100	
			6.3.3	100	
			6.3.3 Figure	101	
			6.3.4	100	

COMPREHENSIVE INDEX

Section No. - Title/Figure/Table	Page Number Access. Revi- Stds. sion No.1	Section No. - Title/Figure/Table	Page Number Access. Revi- Stds. sion No.1
6.3.5	102	* 8.1 Public Toilet Rooms	21
6.3.5 Figure	103	8.1.1	116
6.3.6	102	8.1.2	116
6.3.7	102	8.1.3	118
6.3.7 Figure	103	8.1.4	118
6.3.8	102	8.1.4 Figure	119
6.3.9	102	8.1.5	120
6.3.10	102	8.1.6	120
6.3.10 Figure	103	* 8.1.7	21
* 7 Verticle Circulation	15	- 8.1.7A Revised Figure	23
* 7.1 Elevators	15	- 8.1.7B Revised Figure	23
* 7.1.1	15	- 8.1.7C Revised Figure	24
* 7.1.2	15	8.1.8	124
* 7.1.3	15	* 8.1.9	22
- 7.1.3 Revised Figure	18	8.1.9 Figure	125
* 7.1.4	15	8.1.10	124
* 7.1.5	15	8.1.10 Figure	125
* 7.1.6	16	8.1.11	124
* 7.1.7	16	* 8.1.12	22
- 7.1.7 Revised Figure	16	- 8.1.12 Figure	125
* 7.1.8	16	8.1.13	126
* 7.1.9	16	8.1.13 Figure	127
- 7.1.9 Revised Figure	19	8.1.14	126
* 7.1.10	16	8.1.14 Figure	127
* 7.1.11	17	8.1.15	126
* 7.1.12	17	8.1.16	126
- 7.1.12 Revised Figure	19	9.1 Drinking Fountains	128
* 7.1.13	17	9.1.1	128
* 7.1.14	18	9.1.1 Figure	129
* 7.1.15	18	9.1.2	128
* 7.2 Platform Lift and Chair Lifts	20	9.1.3	130
* 7.2.1	20	9.1.4	130
* 7.2.2	20	9.1.5	130
* 7.2.3	20	9.1.5 Figure	131
		9.1.6	130
		9.1.7	130

COMPREHENSIVE INDEX

Section No. - Title/Figure/Table	Page Number Access. Revi- Stds. sion No.1	Section No. - Title/Figure/Table	Page Number Access. Revi- Stds. sion No.1
10.1 Shower Rooms	132	12.2 Emergency Warning Signals	
10 Figure	133	and Alarms.	144
10.1.1	132	12.2.1	146
10.1.1 Figure	133	12.2.2	146
10.1.2	132	* 12.2.3 (Deleted).	25
10.1.3	132	12.2.4	146
10.1.4	132	12.2.4 Figure	147
10.1.5	132	12.2.5	146
10.1.6	132	12.3 Tactile Warning Signals	
11.1 Coin Operated Public and		and Blind Location Cues.	148
Semi-Public Telephones	134	12.3.1	148
11.1.1	134	12.3.2	148
(-) Figure	135	12.3.3	148
11.1.2	134	12.3.4	148
11.1.3	134	12.3.4 Figure	149
11.1.4	134	12.3.4 Table	149
11.1.5	136	12.3.5	150
11.1.6	136	12.3.6	150
11.1.7	136	12.3.7	150
11.1.8	136	12.3.8	150
11.1.9	136	12.3.9	150
11.1.10	136	13.1 Ground and Floor Surfaces	152
11.1.10 Figure	137	13.1.1	152
11.1.11	136	13.1.2	152
11.1.11 Figure	137	13.1.3	152
11.1.12	138	13.1.4	152
12 Communication and		13.1.5	154
Identification	140	13.1.6	154
12.1 Signage	140		
12.1.1	142	BUILDING PRODUCTS	
* 12.1.2	25	14.1 Location of Controls, Dispensers	
12.1.2 Figure	143	and Receptacles.	156
12.1.3	142	14.1.1	156
12.1.3 Figure	143	14.1.1 Figure	157
12.1.4	142	14.1.2	156
12.1.4 Figure	143	14.1.2 Figure	157
12.1.5	142	14.1.3	156
12.1.6	142	14.1.4	156
12.1.7	144	14.1.5	156
12.1.8	144	14.1.6	158
12.1.8 Figure	145	14.2 Supports	158
		14.2.1	158
		14.2.2	159
		14.2.2 Figure	159

COMPREHENSIVE INDEX

Section No. - Title/Figure/Table	Page Number Access. Revi- Stds. sion No.1	Section No. - Title/Figure/Table	Page Number Access. Revi- Stds. sion No.1
14.2.3	158	16.3 Educational Buildings, Libraries	
14.2.3 Figure	159	and Museums	170
14.2.4	158	16.3.1	170
14.2.5	158	16.3.2	172
14.3 Electrical Fixtures and Controls.	158	16.3.3	172
14.3.1	158	16.3.4	172
14.3.2	158	16.3.5	172
14.3.3	160	16.3.6	172
14.3.4	160	16.3.7	172
14.4 Plumbing Fixtures	160	16.3.8	174
14.4.1	160	16.4 Health Facilities.	174
14.4.2	160	16.4.1	174
14.4.3	160	16.4.2	174
14.4.4	160	16.4.3	174
15.1 Appliances for Public Use	162	16.5 Transportation Terminals	
15.1.1	162	and Stations	174
15.1.2	162	16.5.1	174
15.1.3	162	16.5.2	176
		16.5.3	176
ADDITIONAL REQUIREMENTS FOR SPECIFIC		16.6 Recreation Facilities	176
BUILDINGS TYPES		16.6.1	178
		16.6.2	178
* 16.1 Residential Structures	25	16.7 Auditoria, Azenas, Assembly Halls,	
16.1.1	164	and Stadia	180
16.1.2	164	16.7 Figure	183
16.1.3	164	16.7.1	180
16.1.4	164	16.7.2	180
16.1.4 Figure	165	16.7.2 Table	180
16.1.5	166	16.7.3	180
16.1.6 Figure	167	16.7.3 Figure	181
16.1.7	166	16.7.4	180
16.2 Hotels, Motels.	166	16.7.4 Figure	181
16.2.1	166	16.7.5	182
16.2.2	166	16.7.6	182
16.2.3	168	16.7.6 Table	183
16.2.3 Table	168	16.7.7	184
16.2.4	168	16.7.7 Table	184
16.2.4 Figure	169	* 16.8 Serving Counters, Seating, Fixed	
16.2.4A Figure	171	Tables and Work Surfaces	26
16.2.4B Figure	171	* 16.8.1	26
16.2.5	168	* 16.8.2	26
		- 16.8.2 Revised Figure.	26
		* 16.8.3	26
		- 16.8.3 Revised Figure.	27
		* 16.8.4	26

COMPREHENSIVE INDEX

Section No. - Title/Figure/Table	Access. Std.	Page Number Revi- sion No.1
* 16.8.5		27
* 16.8.6		27
* 16.8.7		27
16.9 Dining Halls - Restaurants	186	
16.9.1	186	
* 16.9.2 (Deleted).		27
* 16.9.3		27
16.9.4	186	
16.9.4 Figure (Same as 12.2.4)	187	
16.9.5	188	
16.10 Shopping Centers - Grocery Stores	188	
16.10.1	188	
16.10.2	188	

REMODELING

* 17.1 Remodeling		28
* 17.1.1		28
* 17.1.2		28
* 17.1.3		28
* 17.1.4		28
* 17.1.5		28
* 17.1.6		29
* 17.2 General Requirements		29
* 17.3 Major Remodeling Requirements		29
* 17.4 Remodeling Requirements - Small Buildings		30
* 17.4.1		30
* 17.4.2		30
* 17.5 Remodeling Requirements - Medium Size Buildings		30
* 17.5.1		30
* 17.5.2		31
* 17.6 Remodeling Requirements - Large Buildings		31
* 17.6.1		31
* 17.6.2		32

HISTORIC PRESERVATION

18.1 Historic Preservation and Historic Reconstruction	198
18.1	198

ACCESSIBILITY STANDARDS, ILLUSTRATED

REVISION NO. 1
(EFFECTIVE . . . MARCH 31, 1981)

1.1.3 DEFINITIONS

APARTMENT BUILDINGS, PRIVATELY OWNED AND FINANCED means all apartment buildings not constructed or financed by the State of Illinois and/or its political subdivisions.

PUBLIC BUILDING MEANS:

- a. A building, structure or improved area owned or leased by this State or its political subdivisions;
- b. A building, structure or improved area used primarily by the general public as a place of gathering or amusement, including but not limited to: theaters, restaurants, hotels and stadia;
- c. Office buildings and factories, not including the second floor of any two-story office building or factory having less than 15,000 square feet at the second floor level nor any occupied levels below grade having less than 15,000 square feet unless the building is publicly owned.

All publicly and privately owned buildings will comply with this Standard except single and two-family residences and the second and third stories of apartment buildings not served by elevators, and privately owned and financed apartment buildings.

1.1.6 REVISIONS TO STANDARDS

These Standards may be revised from time to time by the Capital Development Board. Revised standards shall be published as tentative versions. Public hearings shall be held within three months of publication of the tentative standards, if requested in writing by any interested person. Within six months after the publication of tentative standards, the Capital Development Board shall issue final standards. Tentative and final standards shall be filed with the Secretary of State in accordance with the Illinois Administrative Procedure Act, Ill.Rev.Stat., 1977, Ch. 127, Par. 1001, et seq."

3.5 PARKING

- 3.5.2 When parking areas are provided, they shall have handicapped parking spaces located as close as possible to the shortest accessible path of travel to each building, adjacent street or sidewalk served by that parking area. If passenger loading zones are provided, they shall be accessible to the handicapped and be close to the aforementioned path of travel. If walks are provided through the parking area, they shall follow the requirements of Section 3.2, Walks, Sidewalks.

4.2 DOOR HANDLES

- 4.2.1 All manual door openers shall have a lever design or other shape which does not require grasping and twisting of the wrist as the only means of operation. They shall be mounted 3'-0" to 3'-8" from the floor surface to the center of the actuating portion of the device, see Figure 4.2.1.

Requirements of this Section for the design and shape of manual door openers becomes fully effective July 1, 1981.

- 4.2.6 The hardware provided for doors into hazardous areas (e.g., loading platforms, boiler rooms, electrical switchrooms, stages, etc.), shall be provided with a change in texture, either by knurling or by applying an abrasive finish to the handle.

5.1 INTERIOR CIRCULATION ROUTES

- 5.1.7 Entry control devices shall not prevent access by handicapped persons. When turnstiles or narrow gates are required, alternate access shall be provided immediately adjacent the turnstile.

6.1 RAMPS

- 6.1.1 Any part of a circulation path shall be considered a ramp if it has a slope that is greater than 1:20. Revised Table 6.1.1 gives allowable slopes and maximum lengths. All ramps in a rampway shall have identical slopes. A slope of 1:20 is preferred for ramps of all lengths. The maximum slope of ramps shall be 1:12 in new construction. Ramps of 1:8 and 1:10 may be used where existing physical constraints prevent the construction of more gradually sloped ramps.

6.1.5 All ramps with a rise greater than 9", except curb ramps, shall have handrails on both sides. The handrails shall be 2'-6" to 2'-10" in height, measured vertically from the surface of the ramp, and shall extend at least 1'-0" beyond the top and bottom of the ramp segment. The inside handrail on switchback or dogleg ramps shall be continuous and need not provide the 1'-0" extension except at the top and bottom of the ramp segment. A second set of handrails shall be provided at a height of 2'-0" in elementary schools, nursery schools, and day care centers. Handrails shall be continuous along the ramp segment. Handrails shall comply with Section 6.3, Handrails and Guardrails.

6.1.8 Ramps shall have level platforms at the bottom and the top of each run, at least 5'-0" long and be at least as wide as the ramp. Intermediate platforms shall be 5'-0" minimum between each ramp segment. See Revised Table 6.1.1 for the maximum allowable lengths of ramp segments.

Intermediate turning platforms shall be a minimum of 5'-0" in length and 7'-0" wide to allow wheelchair maneuvering through 180 degrees, and at least 5'-0" long in both directions for turns of 90 degrees. See Revised Figure 6.1.8.

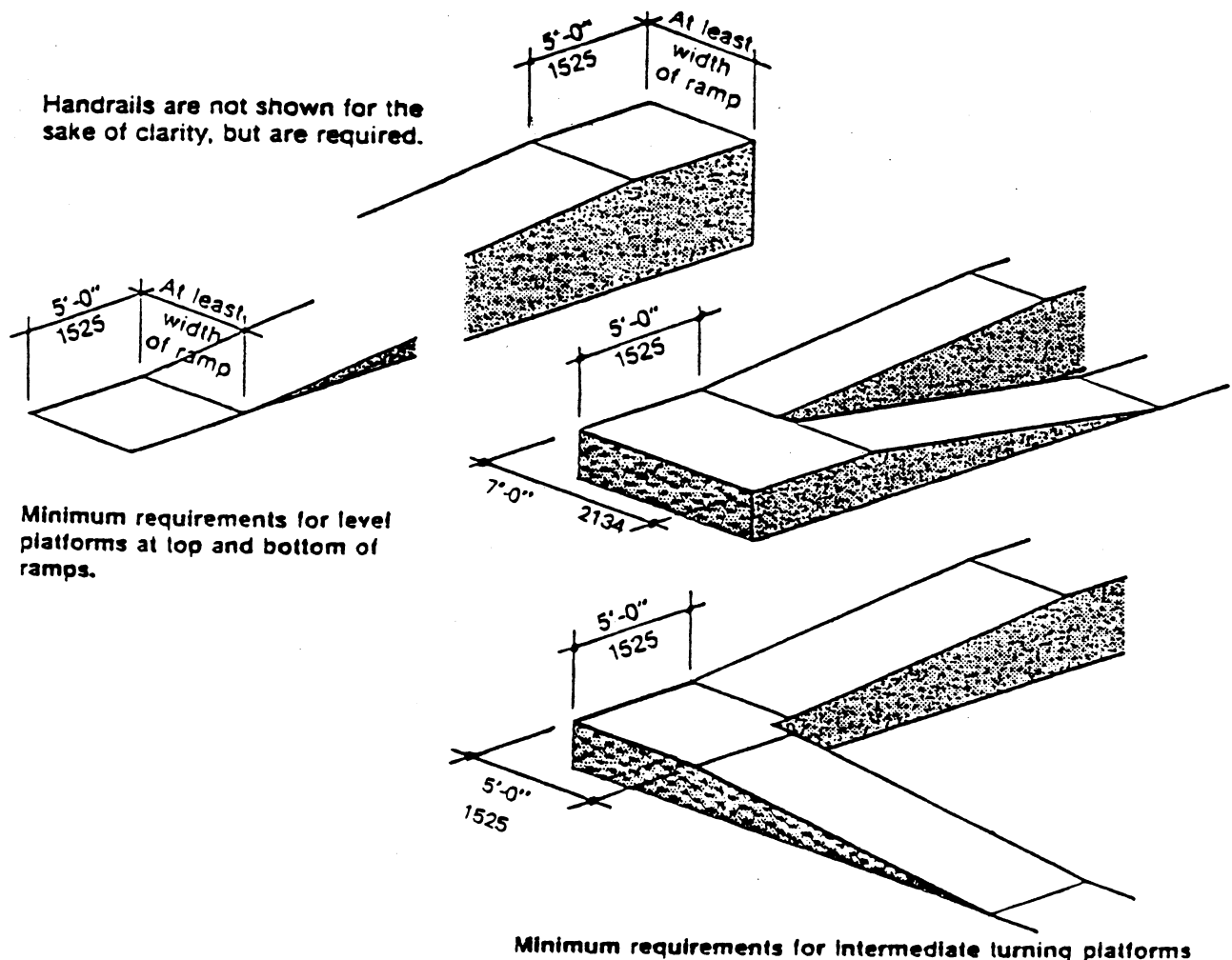

REVISED FIGURE 6.1.8

REVISED TABLE 6.1.1 ALLOWABLE SLOPES AND MAXIMUM LENGTHS OF RAMPS

Allowable Slope	Maximum Rise in a Single Ramp Segment	Total Number of Ramp Segments Permitted	Maximum Length of a Single Ramp Segment	Total Length of Ramp Permitted	Use
1:8	6"	1	4'-0"	4'-0"	Curb ramps when site constraints prohibit 1:12 or 1:10 slope
1:10	9"	1	7'-6"	7'-6"	Curb ramps when site constraints prohibit 1:12 slope
1:12	2'-6"		30'-0"		Curb ramps and ramps.
1:16	2'-6"		40'-0"		Curb ramps and ramps.
1:20	2'-6"		50'-0"		Curb ramps and ramps.

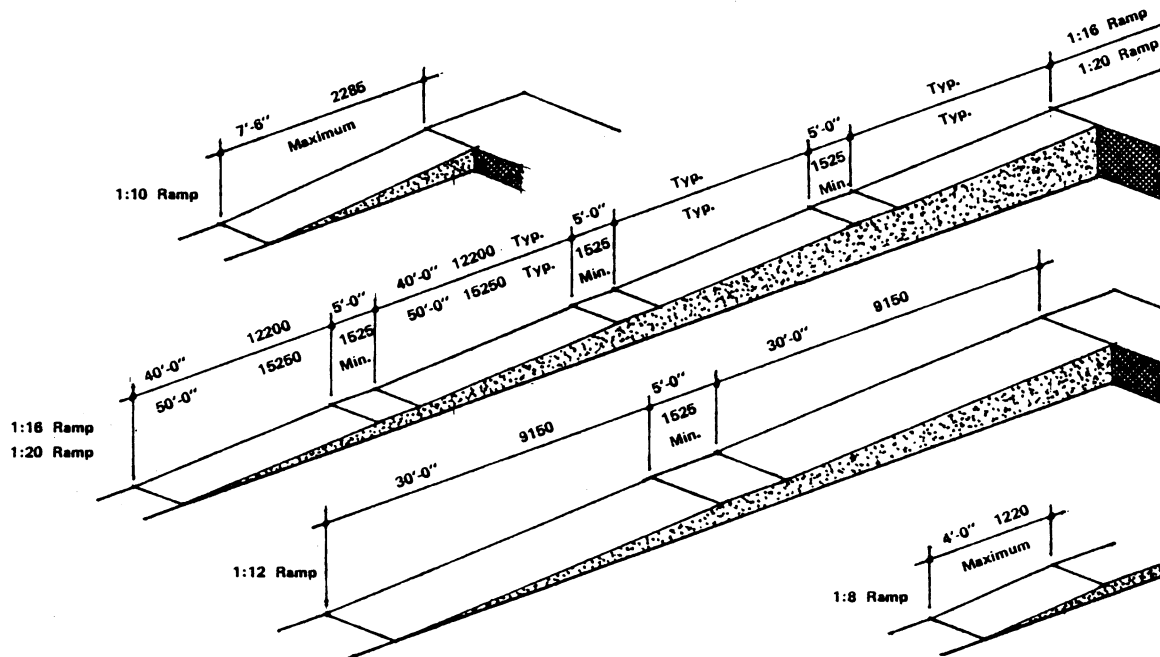

RAMP SLOPES, LENGTHS OF RAMP SEGMENTS AND INTERMEDIATE LANDINGS

REVISED FIGURE 6.1.1 and 6.1.7

6.2 STAIRS

- 6.2.1 All stairs, except as exempted below, shall comply with this section. Stair risers shall be no less than 4" high nor more than 7" high, measured from tread to tread. The minimum width of the tread shall be 11" from nosing to nosing. Stair proportions shall conform to Figure 6.2.1 in order to accommodate the natural informal gait - shown graphically to range from 11" to 14".

EXEMPTION: Exit Stairs which are required by other applicable codes to be separated from all other spaces of the building or structure by construction or equipment having a minimum 1-hour fire resistant rating may have maximum 7½" risers and a minimum tread width of 10".

Escalators shall not be considered as stairs.

TREAD WIDTH IN FEET AND INCHES						RISER		THREAD WIDTH IN MM							
1'-2"	1'-1½"	1'-1"	1'-0¾"	1'-0"	11½"	11"	INCHES	MM	279	292	305	318	330	343	356
							7	178							
							6½	165							
							6	152							
							5½	140							
							5	127							
							4½	114							
							4	102							

ACCEPTABLE RANGE OF TREAD/RISER RELATIONSHIPS

FIGURE 6.2.1

- 6.2.3 Stair treads shall not have abrupt or squared nosing configurations. The leading edge of the tread shall have a radius of curvature no greater than ½" (13mm). Risers shall be sloped or formed with the underside of the nosing at an angle not exceeding 30 degrees from the vertical. Nosings shall project no more than 1½" (38mm). See Revised Figure 6.2.3A. The edge of the nosing shall be clearly distinguishable, see Section 13.1, Ground and Floor Surfaces.

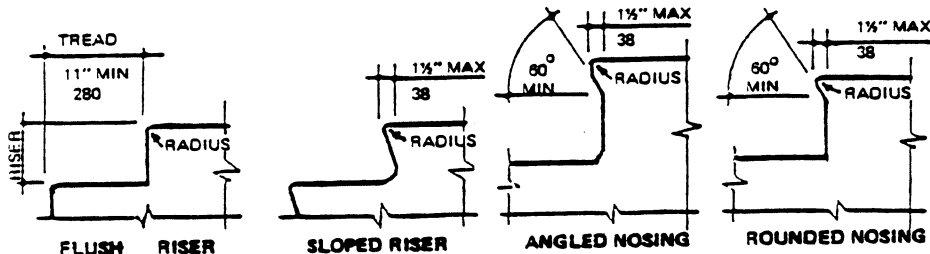

EXAMPLES OF ACCEPTABLE TREAD-RISER-NOSING CONDITIONS

REVISED FIGURE 6.2.3A

- 6.2.6 Stairways shall have continuous handrails on both sides, intermediate handrails as required by Section 6.3.8, and shall be located 2'-6" to 2'-10" measured vertically from the surface of the tread 1" back from the leading edge of the nosing. A second set of handrails shall be provided at a height of 2'-0" in elementary schools, nursery schools, and day care centers. Handrails, except for Exit Stairs exempted under Section 6.2.1, shall extend a minimum of 1'-0" beyond the top riser and 1'-0" plus the tread width beyond the bottom riser except the inside handrail on switchback or dogleg stairs which shall be continuous and not require the horizontal extensions. Handrail extensions shall be parallel with the landing floor surface, see Figure 6.2.6. Guardrails (guards) shall be provided as required by other applicable codes except as called for by Section 6.3. Handrails shall comply with Section 6.3, Handrails or Guardrails.
- 6.2.9 No object shall be hung from above or the sides that projects into a stairway lower than 6'-8" from the surface of any tread or landing, measured vertically. Below that height no object shall project into a stairway other than handrails, stair stringers and door hardware.

7. VERTICAL CIRCULATION

7.1 ELEVATORS

7.1.1 GENERAL

If elevators are provided, all passenger elevators shall be on an accessible route and shall comply with 7.1 and with the American National Standard Safety Code for Elevators, Dumbwaiters, Escalators, and Moving Walks, ANSI A17.1-1978 and A17.1a-1979. This standard does not preclude the use of residential or fully enclosed wheelchair platform lifts when appropriate and approved by administrative authorities as provided in Section 7.2.

7.1.2 AUTOMATIC OPERATIONS

Elevator operation shall be automatic. Each car shall be equipped with a self-leveling feature that will automatically bring the car to floor landings with a tolerance of ½-in (13mm) under rated loading to zero loading conditions. This self-leveling feature shall be automatic and independent of the operating device and shall correct for overtravel or undertravel.

7.1.3 HALL CALL BUTTONS

Call buttons in elevator lobbies and halls shall be centered at 42-in (1065 mm) above the floor. Such call buttons shall have visual signals to indicate when each call is registered and when each call is answered. Call buttons shall be a minimum of ¾-in (19mm) in the smallest dimension. The button designating the up direction shall be on top (see Revised Figure 7.1.3).

7.1.4 HALL LANTERNS

A visible and audible signal shall be provided at each hoistway entrance to indicate which car is answering a call. Audible signals shall sound once for the up direction and twice for the down direction, or shall have verbal annunciators that say "up" or "down". Visible signals shall have the following features:

1. Hall lantern fixtures shall be mounted so that their centerline is at least 72-in (1830mm) above the lobby floor.
2. Visual elements shall be at least 2½-in (64mm) in the smallest dimension.
3. Signals shall be visible from the vicinity of the hall call button. (See Revised Figure 7.1.3). In-car lanterns located in cars, visible from the vicinity of hall call buttons, and conforming to the above requirements, shall be acceptable.

7.1.5 RAISED OR INDENTED CHARACTERS ON HOISTWAY ENTRANCES

All elevator hoistway entrances shall have raised or indented floor designations provided on both jambs. The centerline of the characters shall be 60-in (1525mm) from the floor. Such characters shall be 2-in (50mm) high and shall comply with 12.1. Permanently applied plates are acceptable if they are permanently fixed to the jambs. (See Revised Figure 7.1.3).

7.1.6 DOOR PROTECTIVE AND REOPENING DEVICE

Elevator doors shall open and close automatically. They shall be provided with a reopening device that will stop and reopen a car door and hoistway door automatically if the door becomes obstructed by an object or person. The device shall be capable of completing these operations without requiring contact for an obstruction passing through the opening at heights of 5-in and 29-in (125mm and 735mm) from the floor (see Revised Figure 7.1.3). Door reopening devices shall remain effective for at least 20 seconds. After such an interval, doors may close in accordance with the requirements of ANSI A17.1-1978 and A17.1a-1979.

7.1.7 DOOR AND SIGNAL TIMING FOR HALL CALLS

The minimum acceptable time from notification that a car is answering a call until the doors of that car start to close shall be calculated from the following equation:

$$T = \frac{D}{1.5 \text{ ft/s}} \quad \text{or} \quad T = \frac{D}{455 \text{ mm/s}}$$

where T = total time in seconds and D = distance (in feet or millimeters) from a point in the lobby or corridor 60-in (1525 mm) directly in front of the farthest call button controlling that car to the center-line of its hoistway door (see Revised Figure 7.1.7).

For cars with in-car lanterns, T begins when the lantern is visible from the vicinity of hall call buttons and an audible signal is sounded.

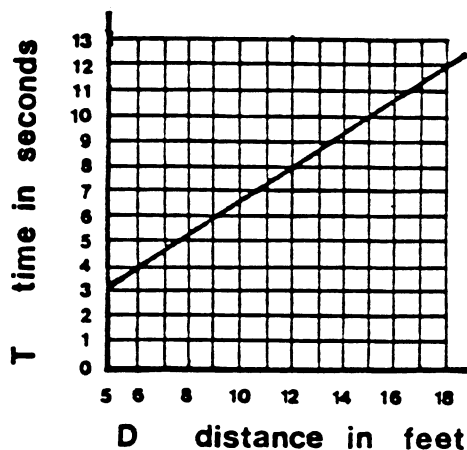

GRAPH OF TIMING EQUATION

REVISED FIGURE 7.1.7

7.1.8 DOOR DELAY FOR CAR CALLS

The minimum time for elevator doors to remain fully open in response to a car call shall be 3 seconds.

7.1.9 FLOOR PLAN OF ELEVATOR CARS

The floor area of elevator cars shall provide space for wheelchair users to enter the car, maneuver within reach of controls, and exit from the car. Acceptable door opening and inside dimensions shall be as shown in Revised Figure 7.1.9. The clearance between the car platform sill and the edge of any hoistway landing shall be no greater than 1¼-in (32mm).

7.1.10 FLOOR SURFACES

Floor coverings shall comply with 13.1.

7.1.11 ILLUMINATION LEVELS

The level of illumination at the car controls, platform, and car threshold and landing sill shall be at least 5 footcandles (53.8 lux).

7.1.12 CAR CONTROLS

Elevator control panels shall have the following features:

1. **Buttons.** All control buttons shall be at least $\frac{3}{4}$ -in (19 mm) in their smallest dimension. They may be raised, flush, or recessed.
2. **Tactile and Visual Control Indicators.** All control buttons shall be designated by raised or indented standard alphabet characters for letters, arabic characters for numerals, or standard symbols as shown in Revised Figure 7.1.12(a), and as required in ANSI A17.1-1978 and A17.1a - 1979. Raised and indented characters and symbols shall comply with Section 12.1. The call button for the main entry floor shall be designated by a raised or indented star at the left of the floor designation (see Revised Figure 7.1.12(a)). All raised or indented designations for control buttons shall be placed immediately to the left of the button to which they apply. Applied plates, permanently attached, are an acceptable means to provide raised or indented control designations. Floor buttons shall be provided with visual indicators to show when each call is registered. The visual indicators shall be extinguished when each call is answered.
3. **Height.** Floor buttons shall be no higher than 54-in (1370 mm) above the floor except that cars with a width of less than 5'-0" shall have floor buttons no higher than 48-in (1220 mm). Emergency controls, including the emergency alarm and emergency stop, shall be grouped at the bottom of the panel and shall have their centerlines no less than 35-in (890 mm) above the floor (see Revised Figure 7.1.12(a) and (b)).
4. **Location.** Controls shall be located on a front wall if cars have center opening doors, and at the side wall or at the front wall next to the door if cars have side opening doors (see Revised Figure 7.1.12(c) and (d)).

7.1.13 CAR POSITION INDICATORS

In elevator cars, a visual car position indicator shall be provided above the car control panel or over the door to show the position of the elevator in the hoistway. As the car passes or stops at a floor served by the elevators, the corresponding numeral shall illuminate and an audible signal shall sound. Numerals shall be a minimum of $\frac{1}{2}$ -in (13mm) high. The audible signal shall be no less than 20 decibels with a frequency no higher than 1500 Hz. An automatic verbal announcement of the floor number at which a car stops or which a car passes may be substituted for the audible signal.

7.1.14 EMERGENCY COMMUNICATIONS

If provided, emergency two-way communication systems between the elevator and a point outside the hoistway shall comply with ANSI A17.1-1978 and A17.1a-1979. The highest operable part of a two-way communication system shall be a maximum of 54-in (1370 mm) from the floor of the car. It shall be identified by raised or recessed symbol and lettering complying with Section 12.1 and located adjacent to the device. If the system uses a handset, then the length of the cord from the panel to the handset shall be at least 29-in (735mm).

7.1.15 HANDRAILS

Handrails shall be provided on the side walls of the car, and preferably on the side and rear walls, mounted at a height between 2'-8" and 3'-0" from the floor of the car. The rail shall have 1½" clearance between the wall and the rail. See Section 6.3 for handrail selection.

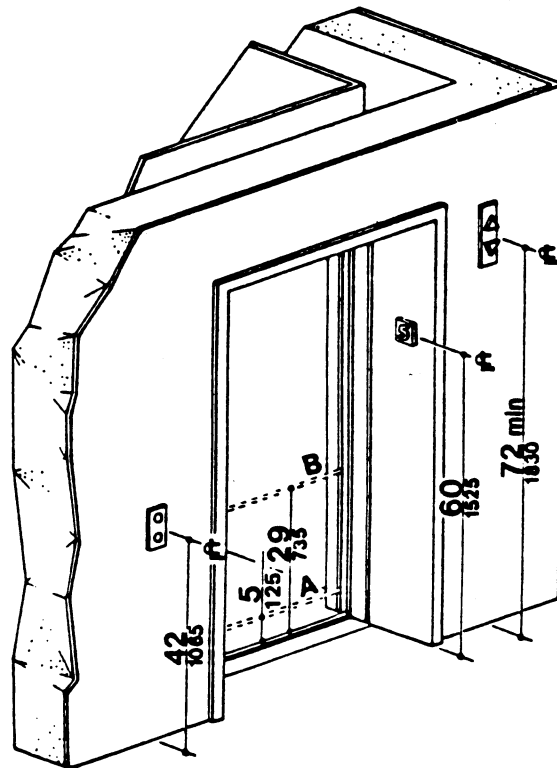

NOTE: The automatic door reopening device is activated if an object passes through either line A or line B. Line A and line B represent the vertical locations of the door reopening device not requiring contact.

HOISTWAY AND ELEVATOR ENTRANCES

REVISED FIGURE 7.1.3

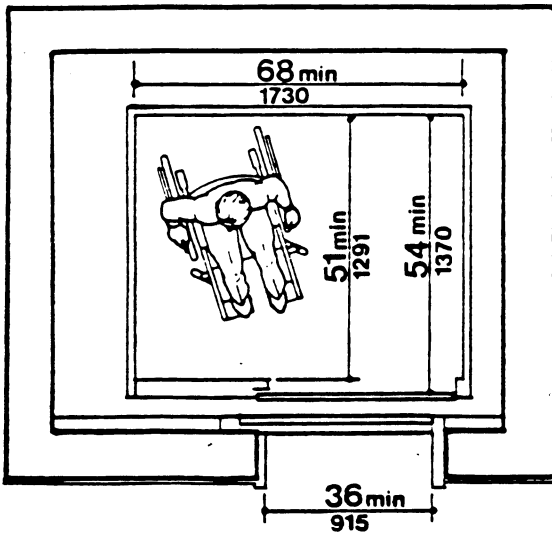

NOTE: Elevator cars with a minimum width less than that at left but no less than 54 in. (1370 mm) are allowed for elevators with capacities of less than 2,000 lbs. A center opening door application may necessitate increasing the 68 in. (1730 mm) dimension.

MIN. DIMENSIONS OF ELEVATOR CARS

REVISED FIGURE 7.1.9

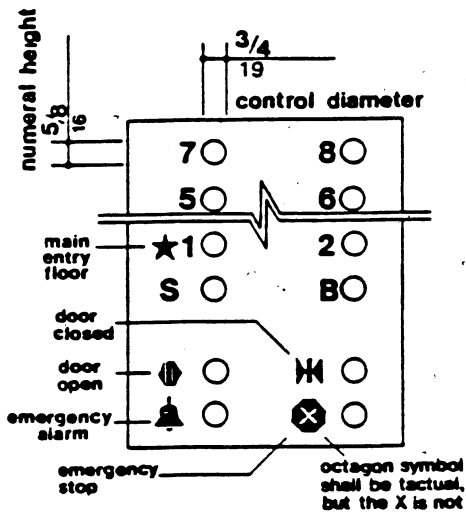

PANEL DETAIL
(a)

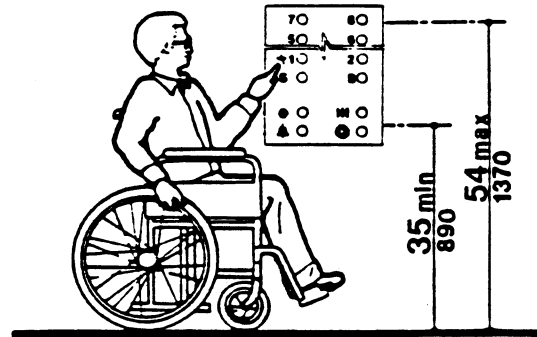

CONTROL HEIGHT
(b)

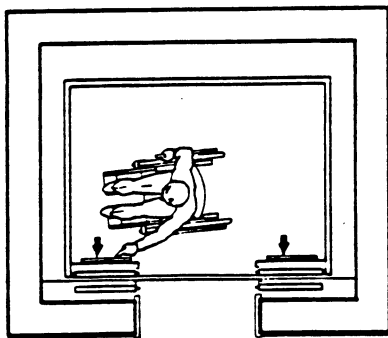

ALTERNATE LOCATIONS OF PANEL WITH CENTER OPENING DOOR
(c)

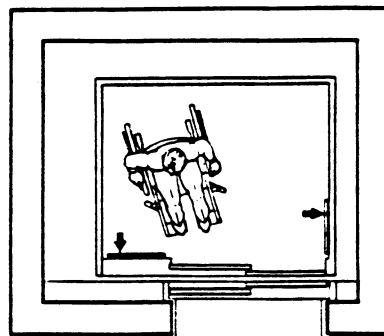

ALTERNATE LOCATIONS OF PANEL WITH SIDE OPENING DOOR
(d)

CAR CONTROLS

REVISED FIGURE 7.1.12

7.2 PLATFORM AND CHAIR LIFTS

7.2.1 USAGE

Platform and chair lifts complying with this section may be used as a part of an accessible route if no other alternative is feasible. Lifts may be of the vertical or inclined travel category.

7.2.2 COMPLIANCE

If platform and/or chair lifts are used, they shall comply:

- a. With applicable portions of the 1981 Supplement to the American National Standards Institute (ANSI) Standard A 17.1-1980, entitled "American National Standard Safety Code for Elevators, Dumbwaiters, Escalators and Moving Walks," as published by the American Society of Mechanical Engineers (ASME).
- b. With applicable safety regulations of administrative authorities having jurisdiction.

7.2.3 REQUIREMENTS

If platform and/or chair lifts are used, they shall meet the following requirements:

- a. Platform lifts shall accommodate an occupied wheelchair within the space provisions required by Section 2.1 (Human Data), Section 2.3.1 (Dimensions of Wheelchairs), and Section 2.3.2 (Space Requirements For Maneuvering Wheelchairs).
- b. Platform lifts shall facilitate unassisted ingress and egress in accordance with Section 4.1 (Entrances, Doors, and Doorways), and Section 13.1 (Ground and Floor Surfaces).
- c. Platform and/or chair lifts shall have accessible controls complying with Section 2.3.3 (Reaching From a Wheelchair), and Section 14.1 (Location of Controls, Dispensers and Receptacles).
- d. Platform and/or chair lifts shall not, in their installation or line of travel, infringe upon the capacity of required exit facilities of the building as established by applicable fire safety regulations.

8.1 PUBLIC TOILET ROOMS

Buildings and occupancies required by code to have a "minimum number of plumbing fixtures" shall have toilet rooms and related fixtures accessible to and usable by handicapped persons as required herein. Design and location of personal hygiene facilities shall provide the same conditions and privacy for all users. Each public toilet room shall have one accessible water closet and related facilities.

The word "public" as used in relation to Toilet Rooms shall be as defined in Section 1.1.3 and shall include facilities required for the use of visitors and employees. "Required" means those Toilet Rooms and numbers of fixtures required by the Illinois State Plumbing Code or any applicable municipal code authorized by the Illinois Plumbing License and Code Law.

- 8.1.7 Public (see Sec. 1.1.3) Toilet Rooms are divided into two categories - those for single person use and those for use by several persons simultaneously. Minimum numbers of fixtures for each sex shall be as required by the Illinois State Plumbing Code or any applicable municipal code authorized by the Illinois Plumbing License and Code Law with the establishment of single or multiple use being the prerogative of the designer.

At least one toilet stall (and its related components) in every public toilet room shall be accessible in accordance with these Standards.

Each public building shall include at least one water closet for each sex which permits side transfer, and at least one water closet which permits side transfer for each sex every fourth floor on multi-story buildings where fixtures are required by the Illinois State Plumbing Code or any applicable municipal code authorized by the Illinois Plumbing License and Code Law. Contingent upon the toilet room category, arrangements of fixture location, clear floor space, toilet stall and door (as required) grab bars, and dispensers shall meet the requirements shown in Revised Figure 8.1.7A, or the Standard Stall of Revised Figure 8.1.7B. All other water closets required to be accessible may follow the requirements for the Alternate Stall, Revised Figure 8.1.7B. Side transfer arrangements may be either right or left handed.

Water closets shall have elongated type bowls, be 17" to 19" from the finished floor to the top of the seat, and seats shall have closed front with covers. Seats and covers shall not be spring loaded and shall be capable of remaining in an upright position. Flushing mechanism shall be automatic or operable with one hand without extremes of bending, reaching or twisting, and shall be activated by a nonprecise movement requiring a light pressure no greater than 5 lbf. Locate controls for flush valves maximum 44" above the floor.

Grab bars complying with the length and positioning shown in the applicable Revised Figures 8.1.7A, 8.1.7B, and 8.1.7C shall be provided. Requirements are not interchangeable. Grab bars may be mounted by any desired method as long as they have a gripping surface at the location shown and do not obstruct the required clear floor area. Grab bars shall not rotate within their fittings. Grab bars shall meet the requirements of Section 14.2, Supports.

A grab bar and any wall or other surface adjacent to it shall be free of any sharp or abrasive elements. Edges shall have a minimum radius of 1/8".

The size and arrangement of accessible toilet stalls shall comply with Revised Figure 8.1.7B. Toilet stalls with a minimum depth of 56" (Standard Stall) or 66" (Alternate Stall) shall have wall-mounted water closets. If the depth of toilet stalls is increased at least 3", then a floor-mounted water closet may be used. In the Standard Stall (Revised Figure 8.1.7B), the front partition and at least one side partition shall provide a toe clearance of at least 9". If the depth of the stall is greater than 60", then the toe clearance is not required.

Toilet stall doors, Revised Figure 8.1.7B, shall swing out and have a 32" clear opening. Opening or locking devices shall not require a pinching or twisting of the wrist to operate. Doors to toilet rooms, Revised Figure 8.1.7A, shall swing out and meet requirements of Sec. 8.1.3, unless the minimum dimensions are increased so that the arc of an inswinging door does not infringe upon the required clear floor space.

Maneuvering space in front of toilet stall door shall be a minimum of 3'-6" in width.

- 8.1.9 At least one lavatory in every public toilet room shall be accessible and usable by people in wheelchairs or who use walking aids. Space planning shall allow front approach to this lavatory, see Section 2.3.2, Space Requirements for Maneuvering Wheelchair. Clearance under lavatory shall be 2'-6" minimum from the floor to the underside of the apron, and 2'-10" maximum to the top of the lavatory bowl, see Figure 8.1.9. There shall be at least 1'-3" clear width to each side of the centerline of the lavatory to facilitate the wheelchair approach. Exposed hot water and drain pipes shall be fully insulated if the water temperature exceeds 105 degrees F. Under-surfaces of lavatory shall be smooth.
- 8.1.12 There shall be sufficient floor area in front of, and under, one accessible wall-mounted urinal in every male public toilet room to allow a wheelchair approach to bring the front edge of the seat to the lip. The urinal shall be mounted with the top of the lip 1'-3" to 1'-5" above the floor surface. There shall be at least 1'-4" clear width to each side of the centerline of the urinal to facilitate the wheelchair approach.

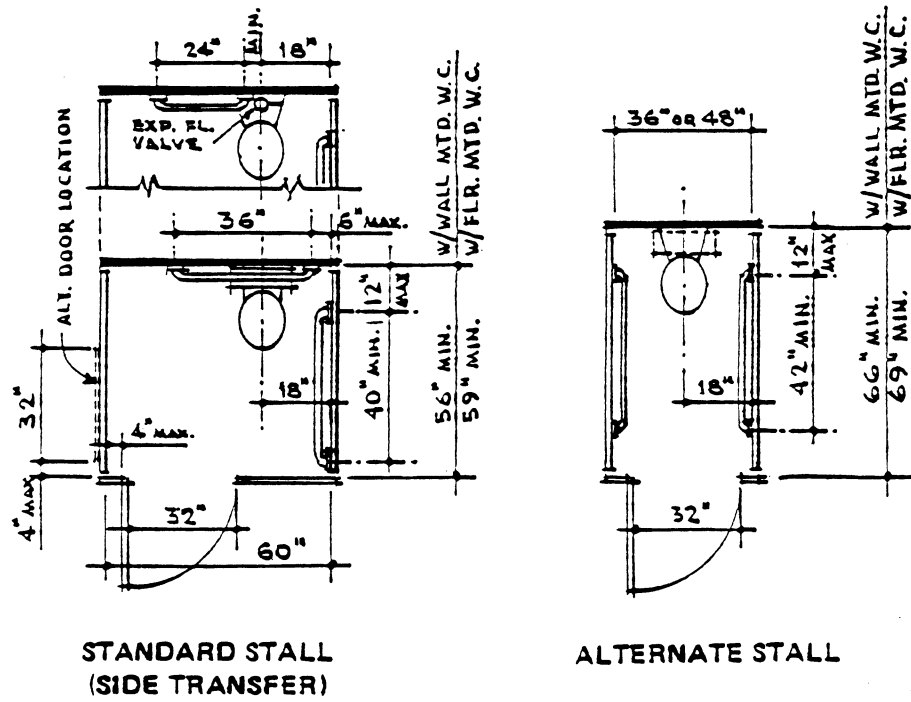
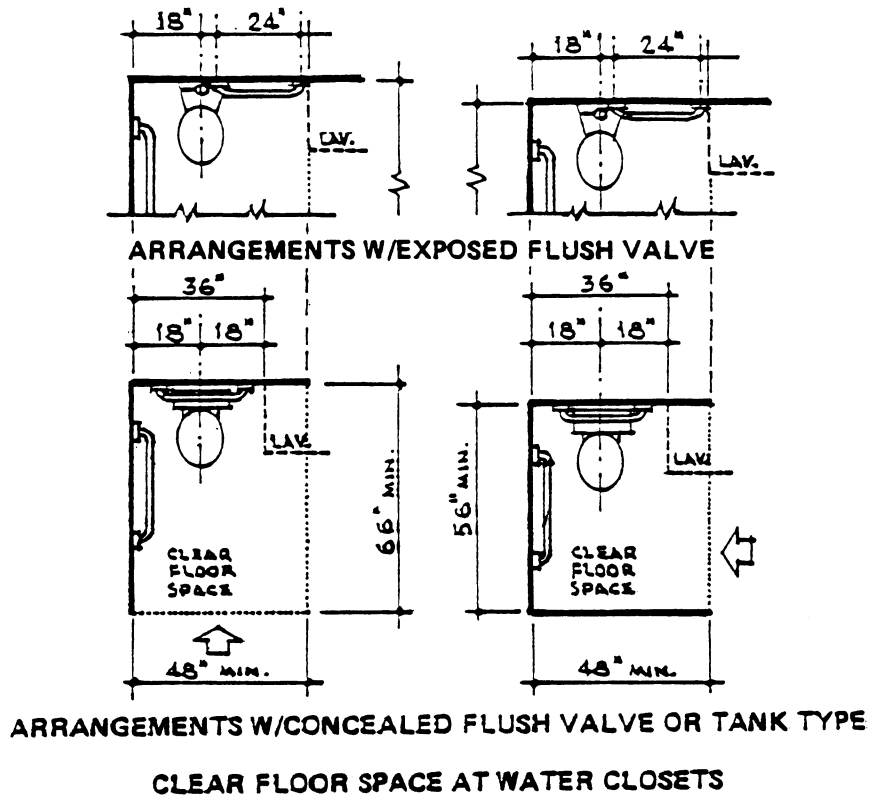

**REAR WALL
W/FLUSH VALVE**

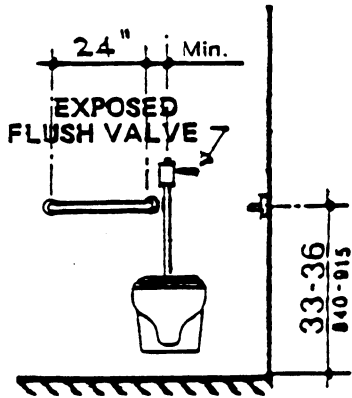

STANDARD STALL

SIDE WALL(S)

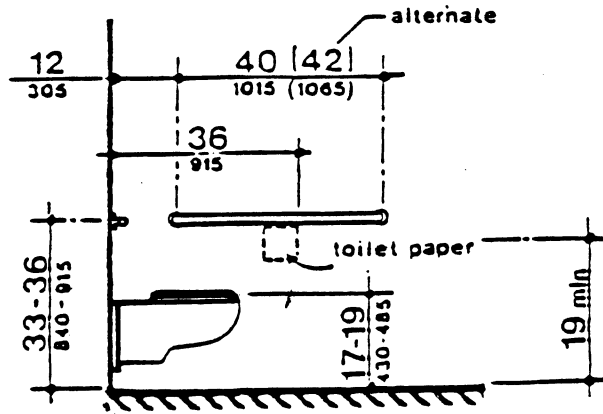

STANDARD OR ALTERNATE STALL

**REAR WALL
W/FLR. MTD. TANK TYPE**

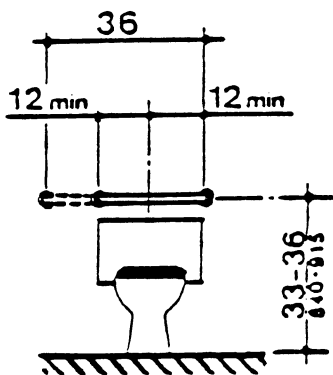

STANDARD STALL

SIDE WALL(S)

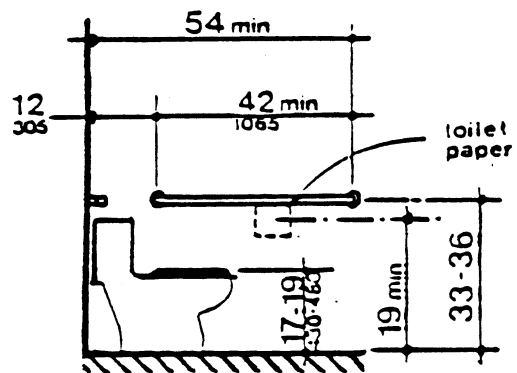

STANDARD OR ALTERNATE STALL

GRAB BARS AT WATER CLOSETS - SEE REVISED FIGURES 8.1.7A & B

REVISED FIGURE 8.1.7C

12.1 SIGNAGE

12.1.2 Where room identification signs and numbers are used, they shall have raised or indented characters. These signs shall be placed in a standardized location throughout the building alongside the door at the latch side, and mounted at a height range of 4'-6" to 5'-0". Characters shall be raised or indented at least 1/32", have sharply defined edges, and be at least 5/8" high.

12.2 EMERGENCY WARNING SIGNALS AND ALARMS

12.2.3 Deleted.

16.1 RESIDENTIAL STRUCTURES

All publicly and privately owned residential structures shall conform to the following requirements except single and two-family residences and the second and third floors of apartment buildings not served by elevators and privately owned and financed apartment buildings. These are minimum requirements and do not satisfy the requirements for specialized housing built expressly for the handicapped or elderly.

16.8 SERVICE COUNTERS, SEATING, FIXED TABLES AND WORK SURFACES

16.8.1 MINIMUM NUMBER

If fixed or built-in service counters, seating, fixed tables or work surfaces are provided in accessible spaces, five percent (5%), but always at least one, of serving counters, seating, fixed tables, or work surfaces shall comply with Section 16.8.

16.8.2 SEATING

Seating spaces for people in wheelchairs (to be provided at tables, counters, or work surfaces) shall be provided with clear floor space complying with Sections 2.3.2, 2.3.3, and 2.3.4. Such clear floor space shall not overlap knee space by more than 19-in (485 mm). See Revised Figure 16.8.2.

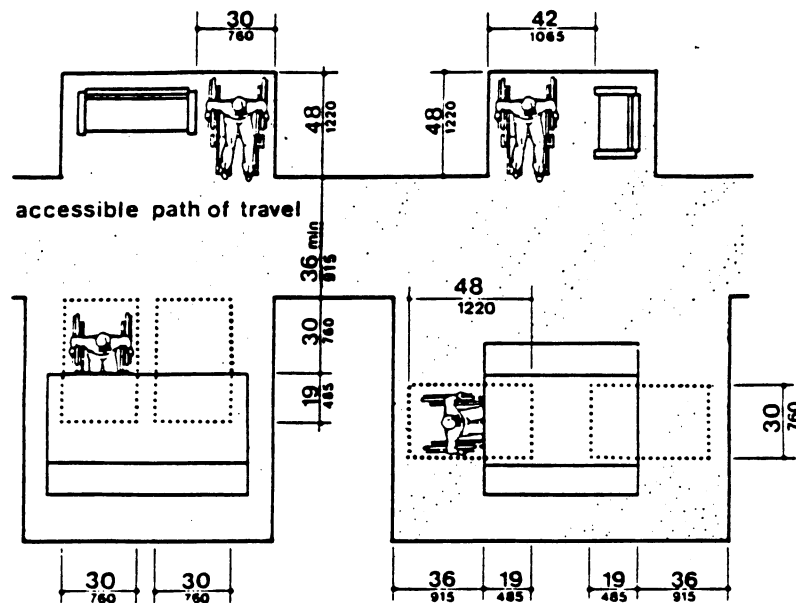

MINIMUM CLEARANCES FOR SEATING AND TABLES

REVISED FIGURE 16.8.2

16.8.3 KNEE CLEARANCES

Seating for people in wheelchairs (to be provided at tables, counters, and work surfaces) shall be provided with knee spaces at least 27-in (685 mm) high, 30-in (760 mm) wide, and 19-in (485 mm) deep. See Revised Figure 16.8.2.

16.8.4 HEIGHT OF WORK SURFACES

The tops of tables, counters, and work surfaces shall be from 28-in to 34-in (710 mm to 865 mm) from the floor or ground.

16.8.5 AUXILIARY SERVICE COUNTERS

Where service counters exceeding 3'-0" in height are provided as standing counters, an auxiliary service counter or other space suitable for the business transaction by the handicapped shall be provided in the immediate vicinity and provide the same services. The auxiliary countertop shall meet the requirements of Sections 16.8.2, 16.8.3, and 16.8.4.

16.8.6 CAFETERIA LINES

(EXISTING SECTION 16.8.6
TRANSFERRED TO SECTION 5.1)

Cafeteria lines shall meet the applicable requirements of Section 5.1, Interior Circulation Routes. In addition, the height of counters for conveying trays shall be 3'-0" maximum; and the maximum reach to any dispenser shall be within reach limitations of wheelchair users unless employees are behind the cafeteria line at all times. See Revised Figure 16.8.3.

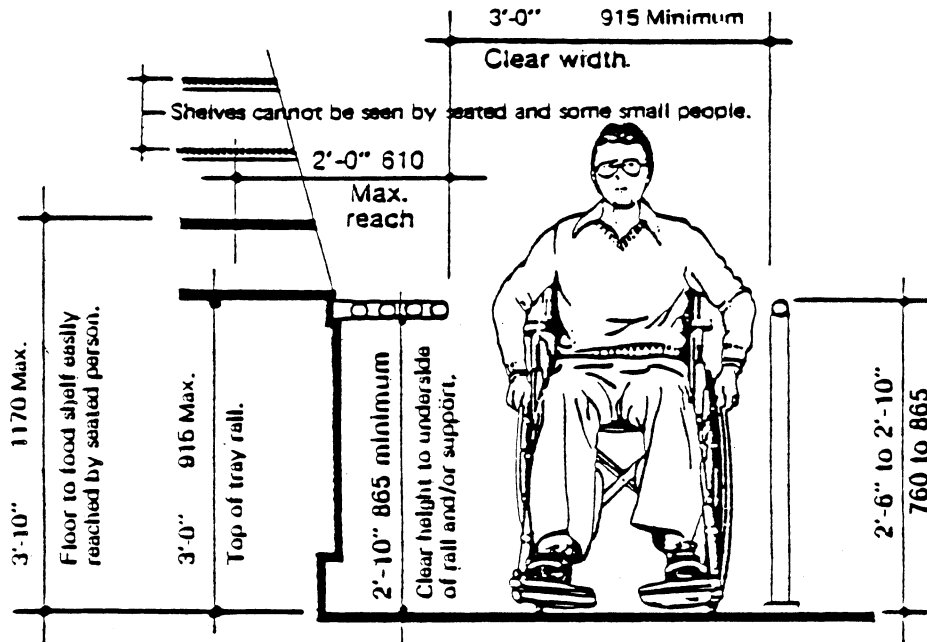

CAFETERIA LINES
REVISED FIGURE 16.8.3

16.8.7 CIRCULATION SPACE

The clear width of the visitor circulation space paralleling service counters shall be in accordance with Revised Figure 16.8.2 and Section 5.1.

16.9 DINING HALLS - RESTAURANTS

16.9.2 Deleted.

16.9.3 The clear width between fixed chairs shall be a minimum of 3'-0" back to back along the main access aisles.

17.1 REMODELING

- 17.1.1 Remodeling embraces rehabilitation and renovation of existing buildings, including improvements, extensions, repairs, structural alteration, changes in design function or layout of various room(s) or rearrangement of the means of egress, or changes in the occupancy group or classification as defined by the applicable building code.

The following items, if undertaken individually within any period of 30 months, shall not be included under remodeling requirements: maintenance; redecoration; replacement of the existing plumbing (except required fixtures), mechanical and electrical systems if not so extensive as to be classified as system rehabilitation; reroofing; tuck-pointing; major facade (store front) rehabilitation except changes to the entrance door; or changes to interior landscaping not in conflict with requirements above but including removal or relocation of non-structural partitions which do not penetrate the finished ceiling. Any work being done to a building shall comply with these Standards. Additions are classified as new work and shall comply with these Standards. The requirements of these Standards are not retroactive. The requirements of this Section (17.1) shall not be construed to exceed requirements for new construction.

- 17.1.2 When the combined total cost of alterations or repairs within any period of 30 months falls within the percentage of reproduction cost shown, those items required by Section 17.1.2 through Section 17.6.2 (as appropriate to the area of the building and the percentage of reproduction cost of the building) shall be provided. Cost of the alterations or repairs shall be construed as the total actual combined cost of such alterations or repairs made within any period of 30 months, including the value of rebates, discounts, free services and other gratuities not normally granted or received in such operations.
- 17.1.3 For the purpose of this section, the reproduction cost of a building or structure shall be the estimated cost of constructing a new building of like size, design and materials at the site of the original structure assuming such site to be clear. The reproduction cost shall be determined by using the recognized standards of an authoritative technical organization.
- 17.1.4 Costs of alterations, additions and repairs as defined in this section shall not include normal maintenance, repairs and replacement of the furnishings or the equipment of a building necessary to maintain the building in the condition required under the ordinance (Code) in effect.
- 17.1.5 When remodeling is carried out in phases, within any period of 30 months, the total remodeling cost shall be used to calculate the requirements of this Standard, irrespective of the number of phases needed to complete the remodeling.

17.1.6 When changes of occupancy (classification or occupancy group as defined by the applicable building code) occur to an existing building or facility, it shall be made accessible to handicapped people, even though other remodeling or renovation may not take place. Section 17.3 shall be followed for the minimum requirements.

17.2 GENERAL REQUIREMENTS

- a. Any remodeling or replacement work to the door(s), frame, and/or hardware of the major entrance of a public building shall result in an accessible entrance.
- b. New restaurants of any capacity constructed in remodeled buildings will require accessible toilet rooms within the building with a travel distance of not more than 200 feet from the restaurant and no more than one floor above or below.
- c. If hardware, controls, dispensers, receptacles, stairs or other features of the building included in this Standard, but not required under Section 17.3 through Section 17.6 are to be replaced or altered, then the requirements of the specific section of this Standard shall be followed.
- d. An accessible horizontal circulation route must be provided to all publicly used spaces WITHIN an area to be remodeled.

17.3 MAJOR REMODELING REQUIREMENTS

Building Area: All categories
less than 3,000 gross sq. ft.
3,000 to 10,100 gross sq. ft.
over 10,000 gross sq. ft.

Remodeling Cost: Over 50% of Reproduction Cost

In this category for public buildings to undergo remodeling, the building, including site requirements, shall conform to all requirements of these standards for new construction.

17.4 REMODELING REQUIREMENTS - Small Buildings

17.4.1 Building Area: Less than 3,000 gross sq. ft.

Remodeling Cost: 25% - 50% of Reproduction Cost

In this category of public buildings to undergo remodeling, the building which is to be remodeled shall conform to these Standards to the extent shown below:

- a. At least one accessible path of travel from a site access point to an accessible entrance shall be provided in those cases where the distance from the property line to the building entrance can accommodate a ramp complying with Section 6.
- b. At least one accessible entrance which is used by the public, but shall not be an entrance used for servicing the building, shall be provided in those cases when an accessible path of travel to the building entrance exists, or is required under "a" above. Existing 5'-0" double-leaf door will suffice.
- c. One accessible toilet room for each sex, if such toilets are required in the building.

17.4.2 Building Area: Less than 3,000 gross sq. ft.

Remodeling Cost: 0 - 25% of Reproduction Cost

In this category of public buildings to undergo remodeling, the building which is to be remodeled shall conform to these Standards to the extent described in Section 17.2, General Requirements.

17.5 REMODELING REQUIREMENTS - Medium Size Buildings

17.5.1 Building Area: 3,000 - 10,000 gross sq. ft.

Remodeling Cost: 25% - 50% of Reproduction Cost

In this category of public buildings to undergo remodeling, the building which is to be remodeled shall conform to these Standards to the extent shown below:

- a. At least one accessible path of travel from a site access point to an accessible entrance shall be provided in those cases where the distance from the property line to the building entrance can accommodate a ramp complying with Section 6.
- b. At least one accessible entrance which is used by the public, but shall not be an entrance used for servicing the building, shall be provided. Existing 5'-0" double-leaf door will suffice.

- c. One accessible toilet room for each sex, if such toilets are required in the building.
- d. Accessible parking places and an accessible path of travel from the parking places to the accessible entrance shall be required where parking is provided. The number and requirements for places for disabled drivers shall conform to Section 3.5, Parking.
- e. Provide accessible vertical circulation to all publicly used spaces. Existing stairs and elevators may be utilized without full compliance with these Standards.

17.5.2 Building Area: 3,000 - 10,000 gross sq. ft.

Remodeling Cost: 0 - 25% of Reproduction Cost

In this category for public buildings to undergo remodeling, the building which is to be remodeled shall conform to these Standards to the extent described in Section 17.2, General Requirements.

17.6 REMODELING REQUIREMENTS - Large Buildings

17.6.1 Building Area: Over 10,000 gross sq. ft.

Remodeling Cost: 25% - 50% of Reproduction Cost

In this category of public buildings to undergo remodeling, the building which is to be remodeled shall conform to these Standards to the extent shown below:

- a. At least one accessible path of travel from a site access point to an accessible entrance shall be provided.
- b. At least one accessible entrance which is used by the public, but shall not be an entrance used for servicing the building, shall be provided. Existing 5'-0" double-leaf door will suffice.
- c. At least one accessible toilet for each sex shall be required for visitors and employees where toilets are provided. In buildings over 4 floors, there shall be one accessible toilet for each sex for every four floors. These toilets shall be on accessible paths of travel from the elevator lobby and shall be marked with the International Symbol of Accessibility on the corridor side of the door. Side access toilets are not required.
- d. Accessible parking places and an accessible path of travel from the parking places to the accessible entrance shall be required where parking is provided. The number and requirements for places for disabled drivers shall conform to Section 3.5, Parking.

- e. Provide accessible vertical circulation to all publicly used spaces. Existing stairs and elevators may be utilized without full compliance with these Standards.
- f. Accessible horizontal paths of travel to and into all publicly-used spaces within the space to be remodeled shall be provided. If the building has elevators, the controls in these elevators shall meet the requirements of Section 7.1.12, Car Controls, and have accessible paths of travel from the lobby to the areas that are to be remodeled.

17.6.2 Building Area: Over 10,000 gross sq. ft.

Remodeling Cost: 0 - 25% of Reproduction Cost

In this category of public buildings to undergo remodeling, the building which is to be remodeled shall conform to these Standards to the extent shown below:

- a. At least one accessible path of travel from a site access point to an accessible entrance shall be provided in those cases where the distance from the property line to the building entrance can accommodate a ramp complying with Section 6.
- b. Provide one accessible toilet room for each sex, if such toilets are required in the building.

STATUTORY REFERENCES

EXCERPTS
FROM
ILLINOIS REVISED STATUTES - 1979

CHAPTER 111½ - PUBLIC HEALTH AND SAFETY

FACILITIES FOR HANDICAPPED ACT

AN ACT to provide facilities for the handicapped in buildings open to the public. Approved June 4, 1965. L. 1965, p. 875. Title as amended Sept. 5, 1967. L.1967, p. 3630.

3701. Short title.] Section 1. This Act shall be known as the Facilities for the Handicapped Act. As amended by act approved Sept. 5, 1967. L. 1967, p. 3630.

3702. Definitions.] Section 2. In this Act

"Public building" means: (a) a building, structure or improved area owned or leased by this State or its political subdivisions: (b) a building, structure or improved area used primarily by the general public as a place of gathering or amusement, including but not limited to: theaters, restaurants, hotels and stadia; (c) office buildings and factories, not including the second floor of any two-story office building or factory having less than 15,000 square feet at the second floor level nor any occupied levels below grade having less than 15,000 square feet unless the building is publicly owned.

"Handicapped person" means a person who, on account of physical, mental, or communicative disability or impairment, is restricted in the use of the built environment because of obstacles which the lack of suitable facilities interpose between the individual and his or her maximum functional level.

"Facility for handicapped persons" includes any ramp, handrail, elevator, door, especially treated surface and similar design, convenience or device which facilitates the health, safety or comfort of a handicapped person.

"Remodel" means with respect to an existing public building to construct an addition or substantially alter the design or layout. Amended by P.A. 80-487, Section 1, eff. Sept. 6, 1977.

3703. Declaration of object.] Section 3. Public buildings which lack facilities for handicapped persons (a) create a substantial risk of death or injury with respect to handicapped persons and others both in normal conditions and in the event of fire, panic or other emergency and (b) impair the full enjoyment of public buildings by handicapped persons. Therefore, facilities for handicapped persons in public buildings are an object of serious public concern. Added by act approved Sept. 5, 1967. L. 1967, p. 3630.

3704. Tentative standards of minimum requirements—Publications—Objections—Hearings—Final Standards.] Section 4. The Capital Development Board shall publish tentative standards of minimum requirements for facilities for handicapped persons in public buildings. The standards shall not require facilities for the handicapped in portions of public buildings which are not open to or used by the general public. Any interested person may submit to the Capital Development Board written objections to the tentative standards. If requested in writing by any interested person, the

Capital Development Board shall hold a public hearing within 3 months of publication of the tentative standards. Any interested person may appear at the hearing and present objections. Within 6 months after the publication of the tentative standards, the Capital Development Board shall issue final standards. The final standards may be revised from time to time by the Capital Development Board. Revised standards shall be published as tentative revisions. The times and procedures for objection, hearing and issuance of final revised standards shall be in accordance with the procedures established in this Section.

Amended by P.A. 79-978, Section 1, eff. Oct. 1, 1975.

3705. Determination that plans and specifications meet standards.] Section 5. One year after approval of this Act, the appropriate contracting authority must determine that the plans and specifications of every public building which the State or any political subdivision, governmental entity or public authority

(a) constructs meets these standards, or

(b) remodels meets these standards to the extent deemed feasible. Added by act approved Sept. 5, 1967. L. 1967, p. 3630.

3706. Requisites for future building permits or authorizations.] Section 6. After the effective date of this amendatory Act of 1975, no building permit or other official authorization for construction of a public building as defined in Section 2. ¹ by any person is valid unless it recites that the plans and specifications meet these standards.

Amended by P.A. 79-979, Section 1, eff. Oct. 1, 1975.

¹ Chapter 111½, Section 3702.

3707. Enforcement—Violations.] Section 6.1. The Attorney General shall investigate any complaint or reported violation of this Act, and where necessary to ensure compliance with this Act the Attorney General may, at any time, bring action for mandamus, injunction or other appropriate relief.

Added by P.A. 79-977, Section 1, eff. Oct. 1, 1975.

3708. Tentative and final standards—Filing.] Section 7. Tentative and final standards shall be filed with the Secretary of State in accordance with "An Act concerning administrative rules", approved June 14, 1951, as now and hereafter amended.¹

Added by act approved Sept. 5, 1967. L.1967, p. 3630.

¹ Chapter 127, Section 1 et seq.

3709. Severability clause.] Section 8. If any provision of this act or application thereof to any person or circumstance is held invalid, such invalidity does not affect other provisions or applications of this Act which can be given effect without the invalid provision or application and to this end the provisions of this Act are declared to be severable.

Added by act approved Sept. 5, 1967. L.1967. p. 3630.

BRAILLE MARKINGS ON ELEVATOR CONTROL DEVICES

AN ACT to require braille markings on control devices for elevators. Approved Aug. 29, 1975 by P.A. 79-658, eff. Oct. 1, 1975.

3801 to 3805. Sections 1 to 5. Repealed by P.A. 80-384, Section 4, eff. Oct. 1, 1977.

TACTILE IDENTIFICATION ON CERTAIN ELEVATORS

AN ACT to require tactile identification for the visually handicapped on certain unsupervised automatic passenger elevator installations, and to repeal an Act therein named. Approved Aug. 29, 1977 by P.A. 80-384, effective Oct. 1, 1977.

3901. Tactile identification or braille markings in elevators.] Section 1. In each building, including commercial, residential and institutional structures, served during regular business hours by an unsupervised automatic passenger elevator for use by the general public, the elevator, or at least the left elevator where there is more than one elevator in any bank of elevators, shall be equipped with elevator controls, within the elevator and at each floor level served by the elevator, which have tactile identification or braille markings, pursuant to the following schedule:

(a) New elevators for which building permits are issued after the effective date of this Act or October 1, 1977, whichever date is later—immediately;

(b) Existing elevators undergoing renovation of control panel for which building permits are issued after effective date of this Act or October 1, 1977, whichever is later—immediately;

(c) Existing elevators not undergoing renovation, the earlier of:

(1) 90 days after the effective date of Federal standards governing elevator control markings applicable to privately owned buildings, or

(2) June 30, 1980.

All tactile identification except braille shall be in contrasting colors and consist of raised letters, numbers, labels or plaques for the visually handicapped.

3902. Offenses—Penalty.] Section 2. (a) Any person, corporation, partnership, association or other entity who, being the owner of, or is otherwise in control of, any unsupervised automatic passenger elevator for use by the general public, and who fails to apply and maintain tactile identification as required by this Act, is guilty of a petty offense, and shall be fined \$100. Each day on which the owner or other person fails to provide the requisite tactile identification constitutes a separate and distinct offense.

(b) Any person who removes the tactile identification required by this Act is guilty of a petty offense and shall be fined \$100.

3903. Enforcement of Act.] Section 3. The provisions of this Act shall be enforced by the State Fire Marshal.

INSTALLATION OF ELEVATORS

AN ACT in relation to the installation of elevators in buildings. Approved Sept. 5, 1975 by P.A. 79-793, eff. Oct. 1, 1975.

4001. Return of elevators to main floor—Two-keyed switch.] Section 1. A two-keyed switch shall be provided at the main floor for each single elevator and for each group of elevators. This keyed switch shall be located in the left door jamb of the elevator entrance. Where there is more than one elevator, the left elevator shall have the switch. The keyed switch shall be located not less than 6'-6" above the floor and approximately 4" below the head jamb. When the switch is in the "On" position, the single elevator and all elevators in a group which are in normal service shall return non-stop to the main floor, and doors shall open. The main floor shall be defined as the floor where keyed switch is located.

(a) An elevator traveling away from the main floor shall reverse at the next available floor without opening its doors and return non-stop to the main floor.

(b) Door re-opening devices for power operated doors which may be affected by smoke or heat so as to prevent door closures shall be rendered inoperative.

(c) Elevators equipped with power operated doors and standing at a floor other than the main or street floor shall close their doors without delay.

(d) The emergency stop button in the car shall be rendered inoperative until the car reaches the main floor.

4002. Emergency service.] Section 2. A keyed switch shall be provided in or adjacent to the operating panel of each elevator. The switch, when operated, shall put the elevator on emergency service.

(a) When on emergency service, an elevator shall be operable only by a person in the car.

(b) Elevators on emergency service shall respond to the car buttons only and shall not be affected in their operations from registered corridor calls.

(c) Power operated doors shall remain closed when the elevator stops at any landing except the main floor until opened by continuous pressure on a door-open button or switch. As soon as the door open button or switch is released, the doors shall automatically reclose.

(d) Where mechanical-electrical safety edge devices are installed on the leading edge of the car doors, these devices shall remain operative and doors may be maintained in open position by operation of the device. Any features that may cause doors to reclose after being held a predetermined time shall be disconnected.

4003. Location of keys.] Section 3. Keys required to call or operate elevators shall be kept in a metal box mounted in a conspicuous location at the main floor. The box shall have a lock type cover. The box shall contain a separate key for each elevator in the group.

4004. Signal to attendant operated elevators.] Section 4. When the elevator or elevators are in control of an attendant, the operation of the key switch shall sound a bell mounted under the car platform as a signal to the attendant to return non-stop to the main floor.

4005. Compliance of attendant operated elevators with this Act.] Section 5. Attendant operated elevators shall comply with all the provisions and operations as required by this Act, except that automatic operation is not required when the car control is manual through a car switch.

4006. Double deck elevator installations-Fireman's emergency control.] Section 6. For double deck elevator installations, the upper deck is to be used for Fireman's Emergency Control and as such will comply with all provisions of this Section.

4007. Firemen's emergency service.] Section 7. Every group of elevators in a building subject to the provisions of this Section shall be available for firemen's emergency service. In buildings where there are several groups of elevators and where individual key switches are provided to cause cars to return to the main floor, this arrangement is satisfactory, provided that a separate key box is provided for each group of elevators.

4008. Application of Act.] Section 8. This Act shall apply to elevators in office, hotel, and factory buildings and all buildings used for residential occupancy in whole or in part where the vertical travel from the main floor to the top terminal floor is 80 feet or over, or to elevators in hospitals where the vertical travel from the main floor to the top terminal floor is 55 feet or over.

4009. Compliance of buildings with this Act.] Section 9. Buildings for which construction commences after December 31, 1975 shall be constructed in compliance with this Act. Buildings in existence or under construction on December 31, 1975, other than hospitals, shall be brought into compliance with this Act not later than January 1, 1979.

4010. Enforcement of Act.] Section 10. The provisions of this Act shall be enforced by the State Fire Marshal.

**CHAPTER 24 – CITIES AND VILLAGES
Municipal Code 1961**

**RAMP ON ALL NEW RECONSTRUCTED CURBS
FOR PERSONS USING
WHEEL CHAIRS REQUIRES**

AN ACT to amend Section 11-80-11 of the "Illinois Municipal Code", approved May 29, 1961, as amended.

Section 11-80-11. The corporate authorities of each municipality may provide for and regulate cross-walks, curbs, and gutters. However, after the effective date of this amendatory Act of 1973, all new curbs which are provided for by any municipality, and all existing curbs which are a part of any reconstruction, within any block which is contiguous to any highway and in which more than 50% of the territory is devoted to or zoned for business, commercial or industrial use shall comply with this Section. In order to enable persons using wheelchairs to travel freely and without assistance, at each cross-walk a ramp with non-slip surface shall be built into the curb so that the sidewalk and street blend to a common level. Such ramp shall be not less than 32 inches wide and shall not have a slope greater than 1 inch rise per 12 inches length. Where because of surrounding buildings or other restrictions it is impossible to conform the slope with this requirement, the ramp shall contain a slope with as shallow a rise as possible under the circumstances. In all ramps there shall be a gradual rounding at the bottom of the slope. Amended by P.A. 78-322, Section 1, eff. Oct. 1, 1973.